

CEILING MOUNTED WORK AREA MONORAILS

20', 25' & 30' SUPPORT CENTERS

- * Ceiling Mounted Work Area Monorail Systems:
- * Steel: Maximum hanger centers Trussed Track (SD) = 20'-0, 25'-0, or 30'-0
Support Distance (SD) is maximum. On multiple bay systems, bay spacing will be divided equally unless otherwise specified.
- * Systems include:

> Hoist Trolley	> Hanger Assemblies	> Festoon Clamps
> Monorail	> Festoon Trolleys	> Festoon Stack-up Section
> Splice Assemblies	> 4-Cond #14 Flat Cable or 1/2" Air Hose	
- * Sway Bracing is required on all Ceiling Mounted **LodeRail** systems for lateral stability. Systems meet all Seismic Zone 4 requirements.
- * Part Number Explanation: _____



Note: Sway bracing (by others) is required on all systems.

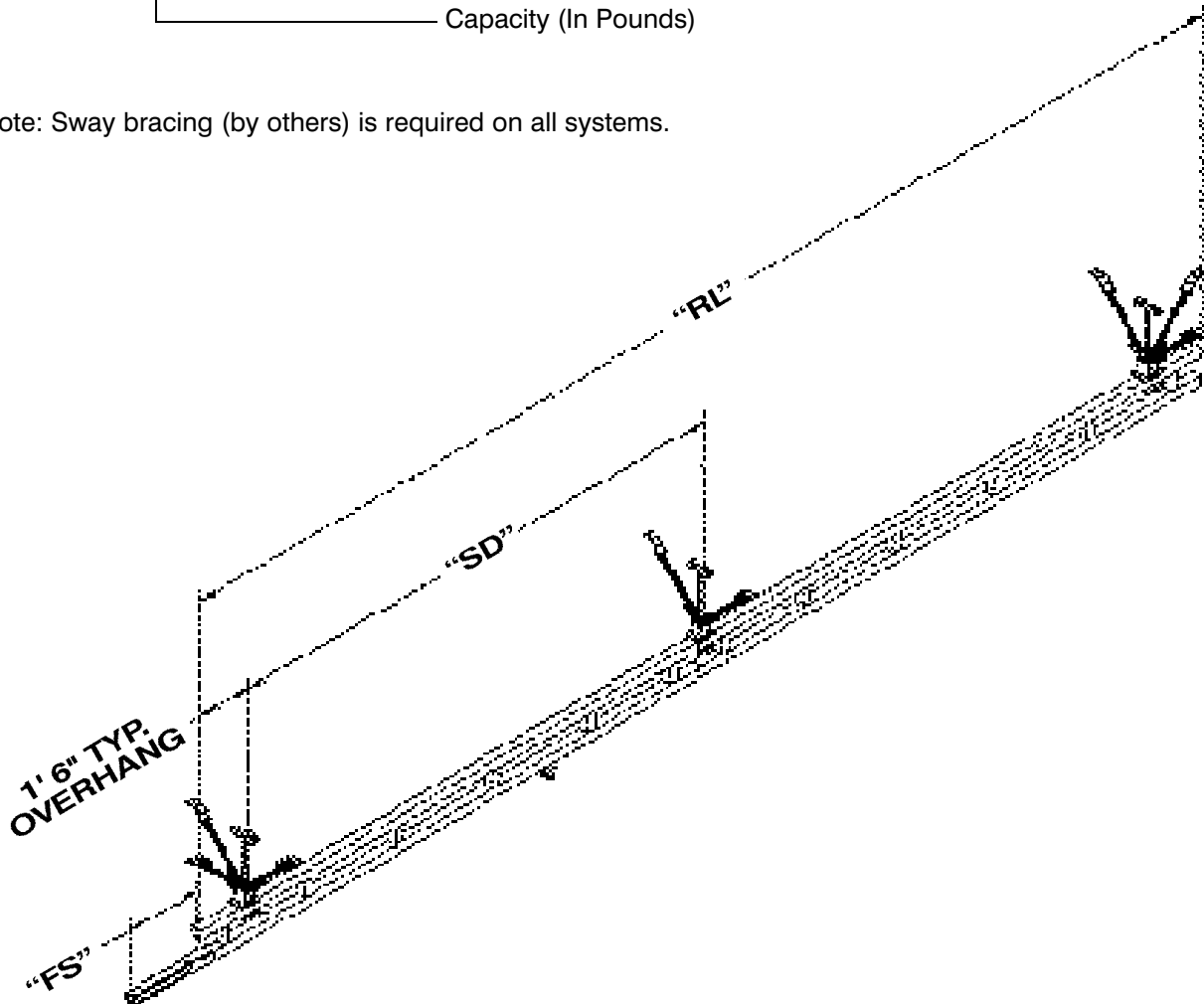

CEILING MOUNTED WORK AREA MONORAILS

6' SUPPORT CENTERS

- * Ceiling Mounted Work Area Monorail Systems:
- * Steel: Maximum hanger centers Plain Track (SD) = 6'-0"
Support Distance (SD) is maximum. On multiple bay systems, bay spacing will be divided equally unless otherwise specified.
- * Systems include:

<ul style="list-style-type: none"> > Hoist Trolley > Monorail > Splice Assemblies 	<ul style="list-style-type: none"> > Hanger Assemblies > Festoon Trolleys > 4-Cond #14 Flat Cable or 1/2" Air Hose 	<ul style="list-style-type: none"> > Festoon Clamps > Festoon Stack-up Section
---	--	--
- * Sway Bracing is required on all Ceiling Mounted **LodeRail** systems for lateral stability. Systems meet all Seismic Zone 4 requirements.
- * Part Number Explanation: _____

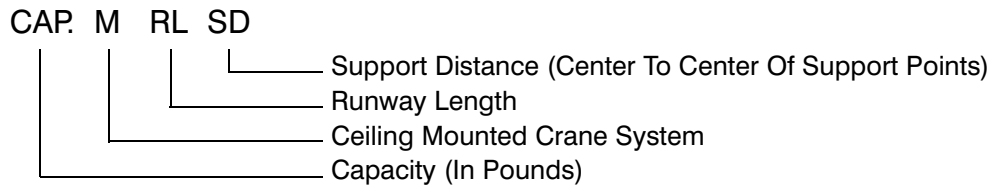

Note: Sway bracing (by others) is required on all systems.

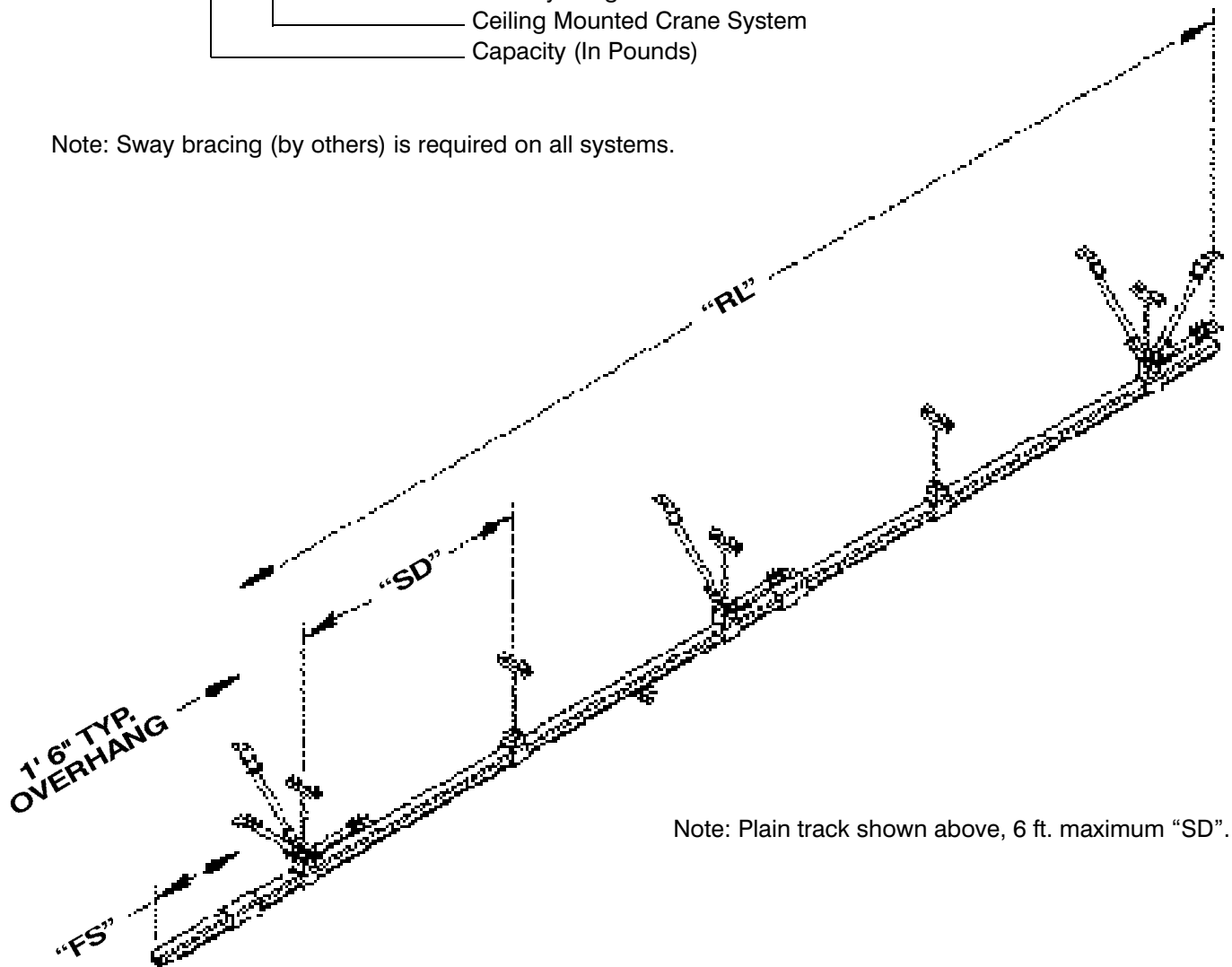

Note: Plain track shown above, 6 ft. maximum "SD".

FREE STANDING WORK AREA MONORAILS 20', 25' & 30' SUPPORT CENTERS

- * Free Standing Work Area Monorail Systems:
- * Steel: Maximum hanger centers Trussed Track (SD) = 20'-0, 25'-0, or 30'-0
Support Distance (SD) is maximum. On multiple bay systems, bay spacing will be divided equally unless otherwise specified.
- * Systems include:

<ul style="list-style-type: none"> > Hoist Trolley > Monorail > Splice Assemblies 	<ul style="list-style-type: none"> > 3" Sq. Tube Stiffeners > Festoon Trolleys > 4-Cond #14 Flat Cable or 1/2" Air Hose 	<ul style="list-style-type: none"> > Festoon Clamps > Festoon Stack-up Section
---	---	--
- * Tube stiffeners are required on all Free Standing Monorail systems for lateral stability. Systems meet all Seismic Zone 4 requirements.
- * Part Number Explanation: _____

CAP. FSM RL SD

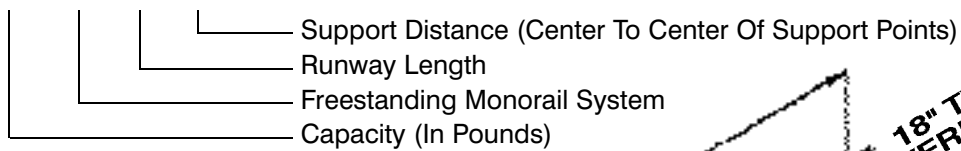

**Call for pricing
on application.
(800) 229-0152**

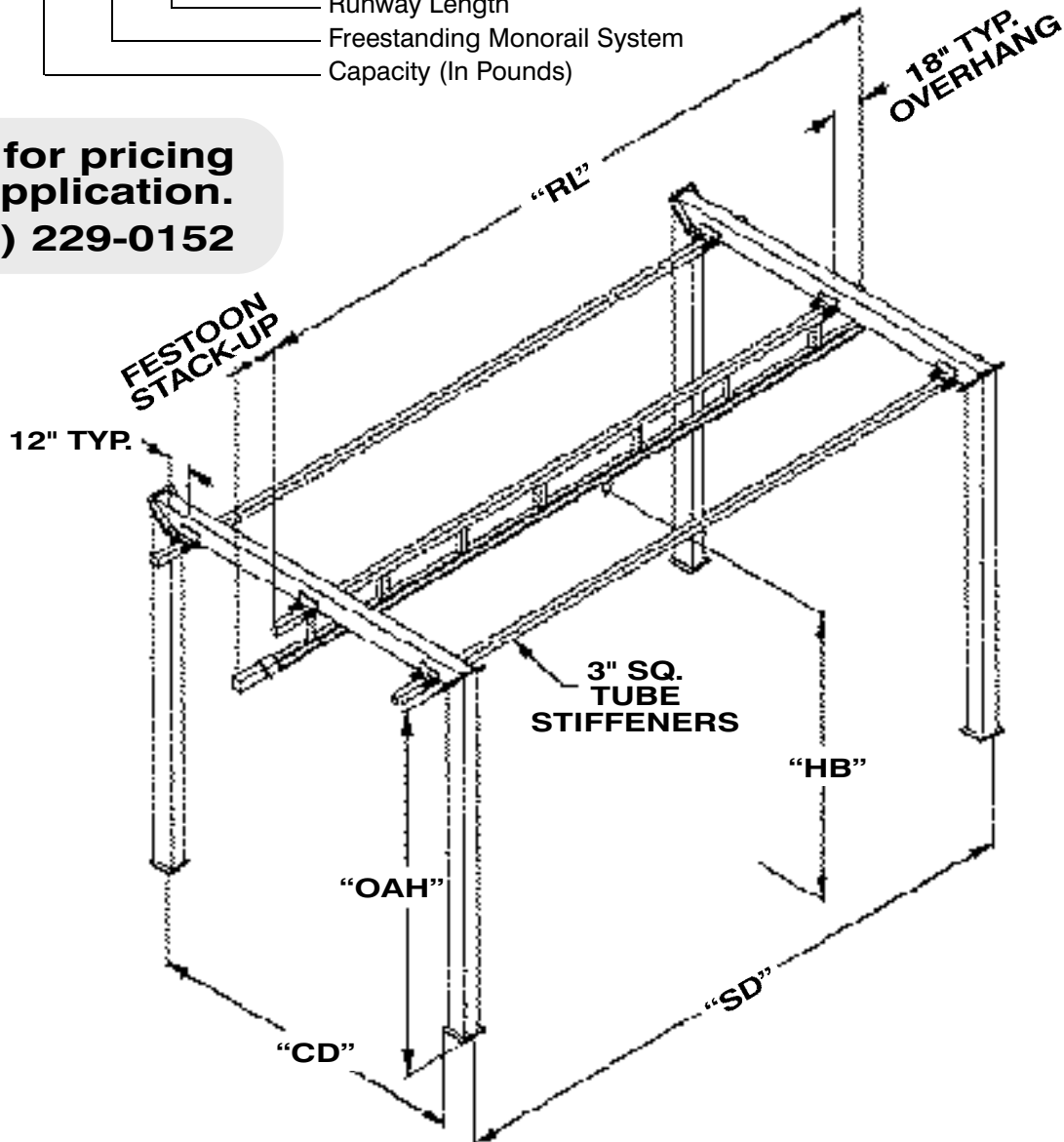



CEILING MOUNTED MONORAILS

RUNWAY LENGTH	SD	NO. OF HANGERS	250# CAPACITY			500# CAPACITY		
			MODEL NUMBER CAP M RL SD	WEIGHT	PRICE	MODEL NUMBER CAP M RL SD	WEIGHT	PRICE
11'-6"	6'	3	250 - M - 11 - 06	110 #	\$623	500 - M - 11 - 06	130 #	\$700
	20'	2	250 - M - 11 - 20	120 #	\$670	500 - M - 11 - 20	150 #	\$742
23'-0"	6'	5	250 - M - 23 - 06	130 #	\$868	500 - M - 23 - 06	185 #	\$1,000
	20'	2	250 - M - 23 - 20	135 #	\$928	500 - M - 23 - 20	200 #	\$1,048
28'-0"	25'	2	250 - M - 28 - 25	245 #	\$1,268	500 - M - 28 - 25	315 #	\$1,490
33'-0"	6'	7	250 - M - 33 - 06	165 #	\$1,048	500 - M - 33 - 06	245 #	\$1,370
	20'	3	250 - M - 33 - 20	175 #	\$1,323	500 - M - 33 - 20	260 #	\$1,497
33'-0"	30'	2	250 - M - 33 - 30	360 #	\$1,519	500 - M - 33 - 30	360 #	\$1,670
43'-0"	6'	9	250 - M - 43 - 06	240 #	\$1,353	500 - M - 43 - 06	350 #	\$1,592
	20'	3	250 - M - 43 - 20	265 #	\$1,754	500 - M - 43 - 20	400 #	\$1,780
53'-0"	6'	11	250 - M - 53 - 06	310 #	\$1,670	500 - M - 53 - 06	450 #	\$1,897
	20'	4	250 - M - 53 - 20	325 #	\$1,918	500 - M - 53 - 20	490 #	\$2,192
	25'	3	250 - M - 53 - 25	460 #	\$2,214	500 - M - 53 - 25	600 #	\$2,627
63'-0"	6'	13	250 - M - 63 - 06	380 #	\$1,897	500 - M - 63 - 06	550 #	\$2,172
	20'	4	250 - M - 63 - 20	420 #	\$2,125	500 - M - 63 - 20	610 #	\$2,459
63'-0"	30'	3	250 - M - 63 - 30	650 #	\$2,806	500 - M - 63 - 30	650 #	\$3,083
78'-0"	25'	4	250 - M - 78 - 25	675 #	\$3,298	500 - M - 78 - 25	885 #	\$4,016
83'-0"	6'	17	250 - M - 83 - 06	430 #	\$2,609	500 - M - 83 - 06	630 #	\$2,968
	20'	5	250 - M - 83 - 20	475 #	\$2,926	500 - M - 83 - 20	715 #	\$3,442
93'-0"	30'	4	250 - M - 93 - 30	970 #	\$4,058	500 - M - 93 - 30	970 #	\$4,459
103'-0"	6'	24	250 - M - 103 - 06	520 #	\$3,143	500 - M - 103 - 06	710 #	\$3,579
	20'	6	250 - M - 103 - 20	565 #	\$3,513	500 - M - 103 - 20	820 #	\$4,207
	25'	5	250 - M - 103 - 25	900 #	\$4,291	500 - M - 103 - 25	1170 #	\$5,249
123'-0"	30'	5	250 - M - 123 - 30	1275 #	\$5,299	500 - M - 123 - 30	1275 #	\$5,823

Price of Monorail System includes:

- >Hoist Trolley
- >Monorail
- >Splice Assemblies
- >Hanger Assemblies
- >Festoon Trolleys
- >4-Cond #14 Flat Cable or 1/2" Air Hose
- >Festoon Clamps
- >Festoon Stack-up Section

NOTE: Hanger Assemblies include threaded rod (up to 72" in length), and hardware for the number of hangers specified. Sway bracing (by others) is required on all systems.

Support Distance (SD) is maximum. On multiple bay systems, bay spacing will be divided equally unless otherwise specified.

For SD Dimension of 6', Center line of splice joints must be within 18" of hanger center line.
 For SD Dimensions of 20', 25', and 30', Center line of splice joints must be within 48" of hanger center line.



CEILING MOUNTED MONORAILS

RUNWAY LENGTH	SD	NO. OF HANGERS	1000# CAPACITY			2000# CAPACITY		
			MODEL NUMBER CAP M RL SD	WEIGHT	PRICE	MODEL NUMBER CAP M RL SD	WEIGHT	PRICE
11'-6"	6'	3	1000 - M - 11 - 06	170 #	\$898	2000 - M - 11 - 06	245 #	\$1,071
	20'	2	1000 - M - 11 - 20	220 #	\$928	2000 - M - 11 - 20	290 #	\$1,119
23'-0"	6'	5	1000 - M - 23 - 06	215 #	\$1,335	2000 - M - 23 - 06	310 #	\$1,652
	20'	2	1000 - M - 23 - 20	280 #	\$1,388	2000 - M - 23 - 20	380 #	\$1,604
28'-0"	25'	2	1000 - M - 28 - 25	510 #	\$1,646	2000 - M - 28 - 25	675 #	\$2,197
33'-0"	6'	7	1000 - M - 33 - 06	310 #	\$1,849	2000 - M - 33 - 06	440 #	\$2,256
	20'	3	1000 - M - 33 - 20	375 #	\$1,981	2000 - M - 33 - 20	525 #	\$2,388
33'-0"	30'	2	1000 - M - 33 - 30	550 #	\$2,053	2000 - M - 33 - 30	735 #	\$2,498
43'-0"	6'	9	1000 - M - 43 - 06	475 #	\$2,125	2000 - M - 43 - 06	660 #	\$2,609
	20'	3	1000 - M - 43 - 20	600 #	\$2,281	2000 - M - 43 - 20	825 #	\$2,747
53'-0"	6'	11	1000 - M - 53 - 06	610 #	\$2,640	2000 - M - 53 - 06	860 #	\$3,190
	20'	4	1000 - M - 53 - 20	760 #	\$2,867	2000 - M - 53 - 20	1040 #	\$3,531
	25'	3	1000 - M - 53 - 25	975 #	\$2,884	2000 - M - 53 - 25	1300 #	\$3,824
63'-0"	6'	13	1000 - M - 63 - 06	770 #	\$3,017	2000 - M - 63 - 06	1040 #	\$3,567
	20'	4	1000 - M - 63 - 20	990 #	\$3,166	2000 - M - 63 - 20	1340 #	\$3,908
63'-0"	30'	3	1000 - M - 63 - 30	1060 #	\$3,382	2000 - M - 63 - 30	1415 #	\$4,303
78'-0"	25'	4	1000 - M - 78 - 25	1670 #	\$4,196	2000 - M - 78 - 25	1920 #	\$6,116
83'-0"	6'	17	1000 - M - 83 - 06	890 #	\$4,064	2000 - M - 83 - 06	1235 #	\$4,794
	20'	5	1000 - M - 83 - 20	1145 #	\$4,333	2000 - M - 83 - 20	1530 #	\$5,320
93'-0"	30'	4	1000 - M - 93 - 30	1565 #	\$4,896	2000 - M - 93 - 30	2100 #	\$6,296
	6'	24	1000 - M - 103 - 06	1045 #	\$4,938	2000 - M - 103 - 06	1410 #	\$5,291
103'-0"	20'	6	1000 - M - 103 - 20	1350 #	\$5,261	2000 - M - 103 - 20	1780 #	\$6,535
	25'	5	1000 - M - 103 - 25	2210 #	\$5,488	2000 - M - 103 - 25	2550 #	\$8,038
	30'	5	1000 - M - 123 - 30	1075 #	\$6,422	2000 - M - 123 - 30	1775 #	\$8,290

Price of Monorail System includes:

- >Hoist Trolley
- >Monorail
- >Splice Assemblies
- >Hanger Assemblies
- >Festoon Trolleys
- >4-Cond #14 Flat Cable or 1/2" Air Hose
- >Festoon Clamps
- >Festoon Stack-up Section

NOTE: Hanger Assemblies include threaded rod (up to 72" in length), and hardware for the number of hangers specified. Sway bracing (by others) is required on all systems.

Support Distance (SD) is maximum. On multiple bay systems, bay spacing will be divided equally unless otherwise specified.

For SD Dimension of 6', Center line of splice joints must be within 18" of hanger center line.

For SD Dimensions of 20', 25', and 30', Center line of splice joints must be within 48" of hanger center line.



CEILING MOUNTED MONORAILS

4000# CAPACITY					
RUNWAY LENGTH	SD	NO. OF HANGERS	MODEL NUMBER		
			CAP	M	RL SD
23'-0	6'	5	4000 - M - 23 - 06	770 #	\$2,088
	20'	2	4000 - M - 23 - 20	875 #	\$2,724
28'-0	25'	2	4000 - M - 28 - 25	1020 #	\$3,023
33'-0	6'	7	4000 - M - 33 - 06	1120 #	\$3,280
	20'	3	4000 - M - 33 - 20	1190 #	\$3,986
43'-0	6'	9	4000 - M - 43 - 06	1320 #	\$3,729
	20'	3	4000 - M - 43 - 20	1340 #	\$4,459
53'-0	6'	11	4000 - M - 53 - 06	1500 #	\$4,555
	20'	4	4000 - M - 53 - 20	1670 #	\$5,728
	25'	3	4000 - M - 53 - 25	1870 #	\$5,297
63'-0	6'	13	4000 - M - 63 - 06	1800 #	\$5,189
	20'	4	4000 - M - 63 - 20	2000 #	\$6,200
78'-0	25'	4	4000 - M - 78 - 25	2720 #	\$7,816
83'-0	6'	17	4000 - M - 83 - 06	2225 #	\$6,721
	20'	5	4000 - M - 83 - 20	2550 #	\$8,199
103'-0	6'	21	4000 - M - 103 - 06	2700 #	\$8,062
	20'	6	4000 - M - 103 - 20	3115 #	\$10,001
	25'	5	4000 - M - 103 - 25	3575 #	\$10,181

Price of Monorail System includes:

- >Hoist Trolley
- >Monorail
- >Splice Assemblies
- >Hanger Assemblies
- >Festoon Trolleys
- >4-Cond #14 Flat Cable or 1/2" Air Hose
- >Festoon Clamps
- >Festoon Stack-up Section

NOTE: Hanger Assemblies include threaded rod (up to 72" in length), and hardware for the number of hangers specified. Sway bracing (by others) is required on all systems.

Support Distance (SD) is maximum. On multiple bay systems, bay spacing will be divided equally unless otherwise specified.

For SD Dimension of 6', Center line of splice joints must be within 18" of hanger center line.
 For SD Dimensions of 20', 25', Center line of splice joints must be within 48" of hanger center line.

(5-15-06)